

**S/A SPRING RETURN CYLINDERS**



Type	<b>SSM</b>
Capacity	5 - 95 ton
Stroke	25 - 362 mm
Max. pressure	700 bar

SSM CYLINDERS



In case of operation under side loads, Larzep can supply tilting saddles.

**CATS**  
Optional Tilting Saddles



P.89

**SSM & D**  
Special attachments for SSM and D models



P.10

**AZ3**  
Coupler 3/8" - 18 NPT included



P.86

**SAM**  
Lightweight Aluminium Cylinders



P.12

**D**  
Double Acting Cylinders



P.40

**J**  
Cylinder and pump sets



P.60

**Models from 75 to 95 ton**

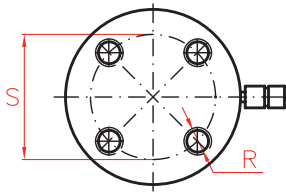

**Models from 5 to 50 ton**

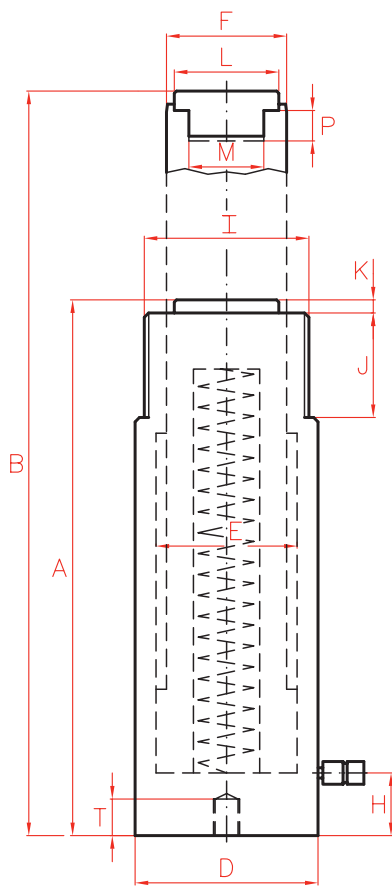
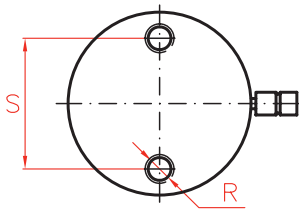

Capacity		Stroke	Model	Oil Cap.	A	B	D	E	F	H	I	
ton	kN	mm	LARZEP	cm <sup>3</sup>	mm	mm	mm	mm	mm	mm	UN	
5	45	25	SSM00502	16	110	135	38	28,6	25,4	19	1 1/2"	- 16 UN
		79	SSM00508	50	165	244	38	28,6	25,4	19	1 1/2"	- 16 UN
		127	SSM00513	83	216	343	38	28,6	25,4	19	1 1/2"	- 16 UN
		177	SSM00518	115	273	450	38	28,6	25,4	19	1 1/2"	- 16 UN
		232	SSM00523	151	324	556	38	28,6	25,4	19	1 1/2"	- 16 UN
10	101	26	SSM01002	38	90	116	57	42,8	38,1	19	2 1/4"	- 14 UN
		54	SSM01005	78	121	175	57	42,8	38,1	19	2 1/4"	- 14 UN
		105	SSM01010	152	171	276	57	42,8	38,1	19	2 1/4"	- 14 UN
		156	SSM01015	226	248	404	57	42,8	38,1	19	2 1/4"	- 14 UN
		203	SSM01020	294	298	501	57	42,8	38,1	19	2 1/4"	- 14 UN
		257	SSM01025	373	349	606	57	42,8	38,1	19	2 1/4"	- 14 UN
		304	SSM01030	441	400	704	57	42,8	38,1	19	2 1/4"	- 14 UN
		356	SSM01035	516	451	807	57	42,8	38,1	19	2 1/4"	- 14 UN
15	142	25	SSM01502	51	124	149	70	50,8	41,3	19	2 3/4"	- 16 UN
		51	SSM01505	104	149	200	70	50,8	41,3	19	2 3/4"	- 16 UN
		101	SSM01510	205	200	301	70	50,8	41,3	19	2 3/4"	- 16 UN
		152	SSM01515	308	271	423	70	50,8	41,3	25	2 3/4"	- 16 UN
		203	SSM01520	411	322	525	70	50,8	41,3	25	2 3/4"	- 16 UN
		254	SSM01525	516	373	627	70	50,8	41,3	25	2 3/4"	- 16 UN
		305	SSM01530	619	424	729	70	50,8	41,3	25	2 3/4"	- 16 UN
		356	SSM01535	723	475	831	70	50,8	41,3	25	2 3/4"	- 16 UN
23	232	26	SSM02302	86	140	166	86	65,1	57,2	25	3 5/16"	- 12 UN
		50	SSM02305	166	165	215	86	65,1	57,2	25	3 5/16"	- 12 UN
		102	SSM02310	339	216	318	86	65,1	57,2	25	3 5/16"	- 12 UN
		158	SSM02315	525	273	431	86	65,1	57,2	25	3 5/16"	- 12 UN
		210	SSM02321	697	324	534	86	65,1	57,2	25	3 5/16"	- 12 UN
		261	SSM02326	867	375	636	86	65,1	57,2	25	3 5/16"	- 12 UN
		311	SSM02331	1033	425	736	86	65,1	57,2	25	3 5/16"	- 12 UN
		362	SSM02336	1202	476	838	86	65,1	57,2	25	3 5/16"	- 12 UN
30	295	209	SSM03021	880	387	596	102	73,0	57,2	29	3 5/16"	- 12 UN
50	498	51	SSM05006	362	176	227	127	95,2	79,4	33	5"	- 12 UN
		101	SSM05010	719	227	328	127	95,2	79,4	33	5"	- 12 UN
		159	SSM05016	1131	283	442	127	95,2	79,4	35	5"	- 12 UN
		260	SSM05025	1855	384	644	127	95,2	79,4	35	5"	- 12 UN
		337	SSM05034	2399	460	797	127	95,2	79,4	35	5"	- 12 UN
75	718	156	SSM07516	1601	286	442	146	114,3	95,3	30	5 3/4"	- 12 UN
		333	SSM07533	3417	492	825	146	114,3	95,3	30	5 3/4"	- 12 UN
95	933	51	SSM10006	676	219	270	178	130,2	104,8	41	6 7/8"	- 12 UN
		168	SSM10015	2239	357	525	178	130,2	104,8	41	6 7/8"	- 12 UN
		260	SSM10026	3466	449	709	178	130,2	104,8	41	6 7/8"	- 12 UN

\*SSM01002 plunger top has 2 holes

\*10-24UNC separated 19mm and does not include removable saddle



	J	K	L	M	P	R	S	T	Area	Weight	Model	With tilting saddle	
	mm	mm	mm	UN	mm	UN	mm	mm	cm <sup>2</sup>	kg	LARZEP	A	Model
	28	6	25	3/4" - 16	14	1/4" - 20	25	14	6,4	1,0	SSM00502	-	-
	28	6	25	3/4" - 16	14	1/4" - 20	25	14	6,4	1,5	SSM00508	-	-
	28	6	25	3/4" - 16	14	1/4" - 20	25	14	6,4	1,9	SSM00513	-	-
	28	6	25	3/4" - 16	16	1/4" - 20	25	14	6,4	2,4	SSM00518	-	-
	28	6	25	3/4" - 16	16	1/4" - 20	25	14	6,4	2,8	SSM00523	-	-
	27	-	-	#10 - 24	6	5/16" - 18	40	12	14,4	1,8	SSM01002	-	-
	27	6	35	1" - 8	19	5/16" - 18	40	12	14,4	2,3	SSM01005	136	CATS12
	27	6	35	1" - 8	19	5/16" - 18	40	12	14,4	3,3	SSM01010	186	CATS12
	27	6	35	1" - 8	19	5/16" - 18	40	12	14,4	4,4	SSM01015	263	CATS12
	27	6	35	1" - 8	19	5/16" - 18	40	12	14,4	5,4	SSM01020	313	CATS12
	27	6	35	1" - 8	19	5/16" - 18	40	12	14,4	6,4	SSM01025	364	CATS12
	27	6	35	1" - 8	19	5/16" - 18	40	12	14,4	6,8	SSM01030	415	CATS12
	27	6	35	1" - 8	19	5/16" - 18	40	12	14,4	8,2	SSM01035	466	CATS12
	30	9	38	1" - 8	25	3/8" - 16	48	12	20,3	3,3	SSM01502	135	CATS12
	30	9	38	1" - 8	25	3/8" - 16	48	12	20,3	4,1	SSM01505	160	CATS12
	30	9	38	1" - 8	25	3/8" - 16	48	12	20,3	5,0	SSM01510	211	CATS12
	30	9	38	1" - 8	25	3/8" - 16	48	12	20,3	6,8	SSM01516	282	CATS12
	30	9	38	1" - 8	25	3/8" - 16	48	12	20,3	8,2	SSM01520	333	CATS12
	30	9	38	1" - 8	25	3/8" - 16	48	12	20,3	9,5	SSM01525	384	CATS12
	30	9	38	1" - 8	25	3/8" - 16	48	12	20,3	10,9	SSM01530	435	CATS12
	30	9	38	1" - 8	25	3/8" - 16	48	12	20,3	11,8	SSM01535	486	CATS12
	49	10	51	1 1/2" - 16	25	1/2" - 13	59	19	33,3	5,9	SSM02302	155	CATS52
	49	10	51	1 1/2" - 16	25	1/2" - 13	59	19	33,3	6,4	SSM02305	180	CATS52
	49	10	51	1 1/2" - 16	25	1/2" - 13	59	19	33,3	8,2	SSM02310	231	CATS52
	49	10	51	1 1/2" - 16	25	1/2" - 13	59	19	33,3	10,0	SSM02315	288	CATS52
	49	10	51	1 1/2" - 16	25	1/2" - 13	59	19	33,3	12,2	SSM02321	339	CATS52
	49	10	51	1 1/2" - 16	25	1/2" - 13	59	19	33,3	14,1	SSM02326	390	CATS52
	49	10	51	1 1/2" - 16	25	1/2" - 13	59	19	33,3	16,3	SSM02331	440	CATS52
	49	10	51	1 1/2" - 16	25	1/2" - 13	59	19	33,3	17,7	SSM02336	491	CATS52
	49	10	51	1 1/2" - 16	25	1/2" - 13	59	16	42,9	18,1	SSM03021	402	CATS52
	55	2	71	—	—	1/2" - 13	95	19	71,3	15,0	SSM05006	191	CATS100
	55	2	71	—	—	1/2" - 13	95	19	71,3	19,1	SSM05010	242	CATS100
	55	2	71	—	—	1/2" - 13	95	19	71,3	23,1	SSM05016	298	CATS100
	55	2	71	—	—	1/2" - 13	95	19	71,3	31,8	SSM05025	399	CATS100
	55	2	71	—	—	1/2" - 13	95	19	71,3	37,6	SSM05034	475	CATS100
	44	2	71	—	—	5/8" - 13	114	16	102,6	29,5	SSM07516	302	CATS100
	44	2	71	—	—	5/8" - 13	114	16	102,6	59,0	SSM07533	508	CATS100
	44	2	71	—	—	3/4" - 10 UNC	140	25	133,1	36,7	SSM10006	235	CATS100
	44	2	71	—	—	3/4" - 10 UNC	140	25	133,1	59,0	SSM10015	373	CATS100
	44	2	71	—	—	3/4" - 10 UNC	140	25	133,1	72,6	SSM10026	465	CATS100

## ATTACHMENTS FOR SSM AND D MODELS

### Base Plate

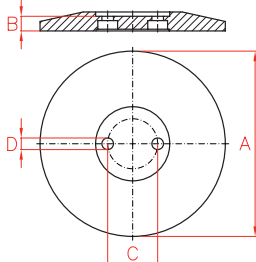

Capacity (ton)		Model	A	B	C	D	Weight
SSM	D	LARZEP	mm	mm	mm	mm	kg
10	10	SM010P	180	15	39	8,5	2,7
15	-	SM015P	180	15	47	10,0	2,7
23	20	SM023P	215	17	58	13,5	4,9
30	30	SM030P	215	17	66	13,5	4,9

### Mounting Block

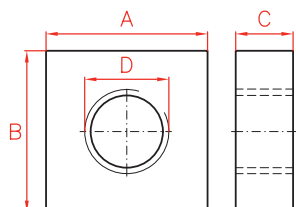
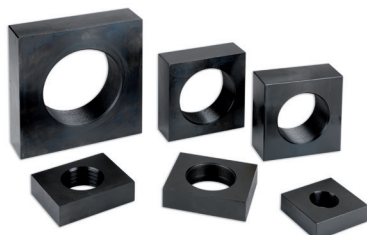

Capacity (ton)		Model	A	B	C	D
SSM	D	LARZEP	mm	mm	mm	UN
5	-	RB5	88	76	25	1 1/2"-16 UN
10	10	RB10	114	88	25	2 1/4"-14 UN
15	-	RB15	114	101	38	2 3/4"-16 UN
23	-	RB25	165	127	50	3 5/16"-12UN

### Collar Toe

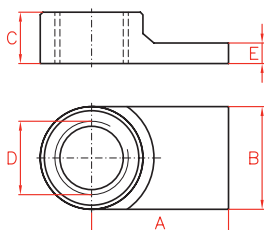

### WARNING

When using this accessory do not exceed 350 bar.

Capacity (ton)		Model	A	B	C	D	E
SSM	D	LARZEP	mm	mm	mm	UN	mm
5	-	A1034	59	32	50	1 1/2"-16UN	11
10	10	A20	79	57	57	2 1/4"-14UN	14
23	-	A595	103	80	51	3 5/16"-12UN	40



Clevis Eye Body

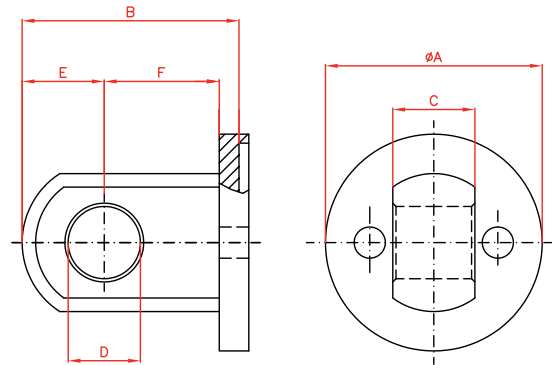

Capacity (ton)		Model	A	B	C	D	E	F
SSM	D	LARZEP	mm	mm	mm	mm	mm	mm
5	-	REB5	44	47	14	16	16	25
10	-	REB10	63	66	25	22	25	35
15	-	REB15	76	66	25	22	25	35
23	20	REB25	95	79	38	31	31	41

Clevis Eye Piston

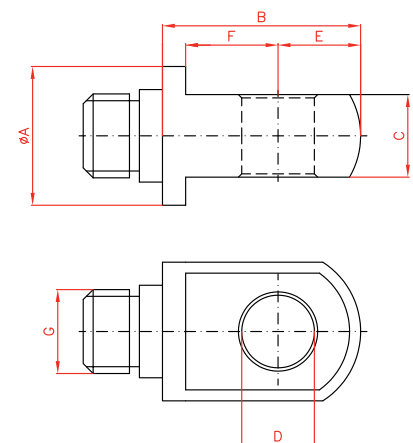

Capacity (ton)		Model	A	B	C	D	E	F	G
SSM	D	LARZEP	mm	UN	mm	mm	mm	mm	UN
5	-	REP5	28	45	14	16	16	19	3/4"-16 UN
10-15	10-20	REP10	42	61	25	22	25	28	1"-8UN
23	30	REP25	57	71	38	31	31	35	1 1/2"-16UN